

Building an iHD1500 Endpoint

David W. Fleig, Computing & Information Technology



iHD1500

- Collaboration tool
- High-fidelity interaction
 - Accurate, precise reproduction
 - Picture, sound, motion
 - Low latency
 - Temporal accuracy
 - Real time operation
- IP Video
 - Expands the definition
- University of Washington
- University of Michigan



Motivation

- STIET IGERT
- MiLR
- Collaboration needs
- More immersive experience
- Desired higher fidelity than traditional VC
 - Low latency
 - Real time
- Explore advanced technology
- Explore partnerships
- Ease travel



MiLR

- Michigan Lambda Rail
- High Speed Regional Optical Network

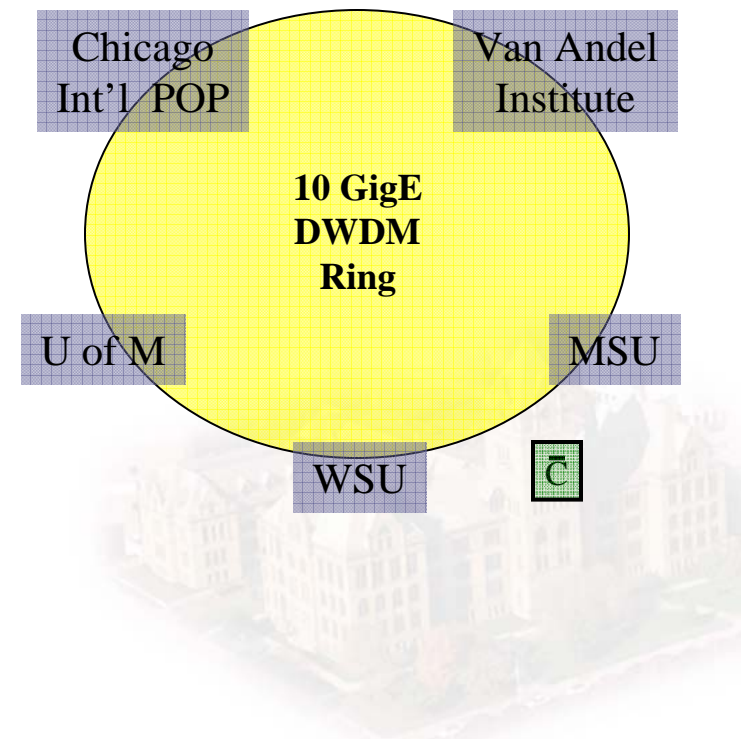

Ingredients

- 10 GigE network
- Endpoint hardware
 - HP xw8400 workstations
 - I/O cards
 - HD SDI
 - Dual Intel NIC
 - Jumbo frames
 - Load sharing
 - Real time, uncompressed HD via Copper UTP
 - No fiber to the desktop
 - Audiovisual system
- Endpoint Software
 - Cygwin
 - iHD1500
 - University of Washington
 - Windows XP
 - HD SDI drivers



Performance Conditions

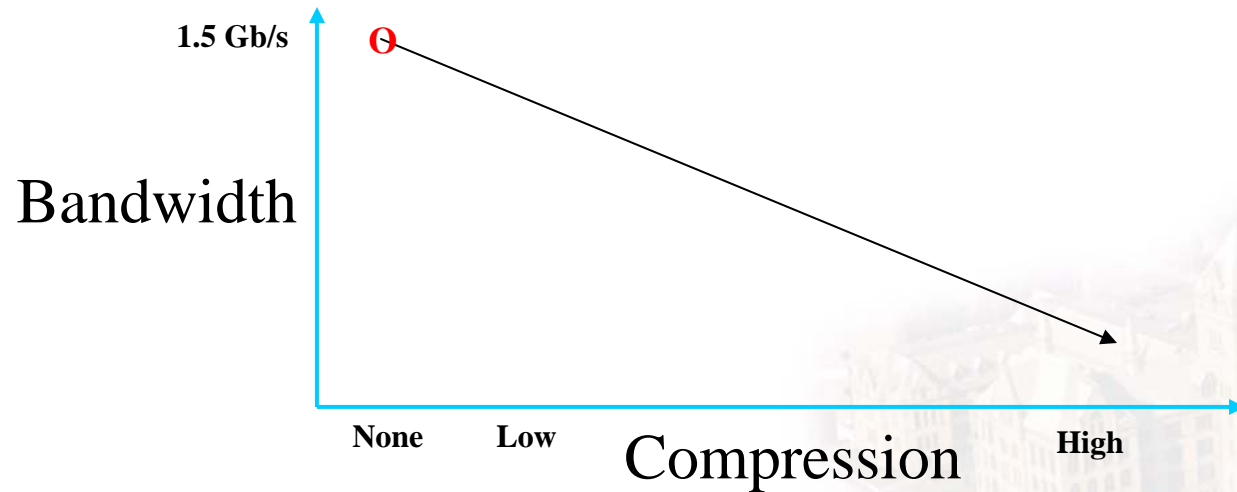
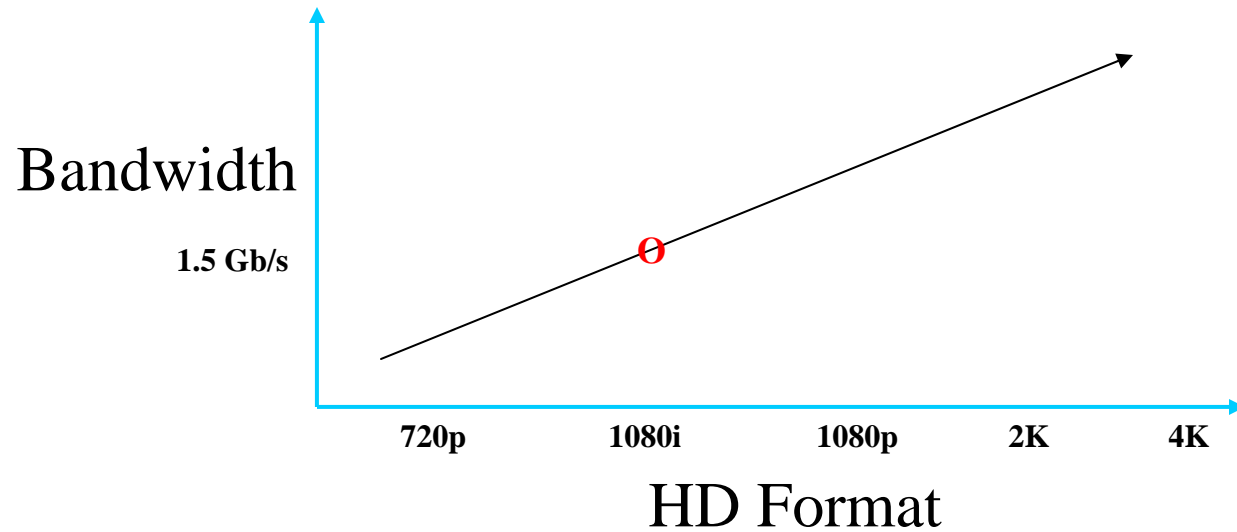

Issues

- Precedent
 - Little or none
- 10G Networking
 - Production networks not feasible
- 1080i HDTV uncompressed ~ 1.5 Gbits / second
- HP xw8400 config
 - HD SDI cards
 - Strange HP NIC Ops
- Windows XP
 - Configuration
 - Security
- Vendor/System Integrator familiarity
 - Typical classroom hardware may not work
 - HD best practices
- Standards
 - SMPTE, AES



Diagram

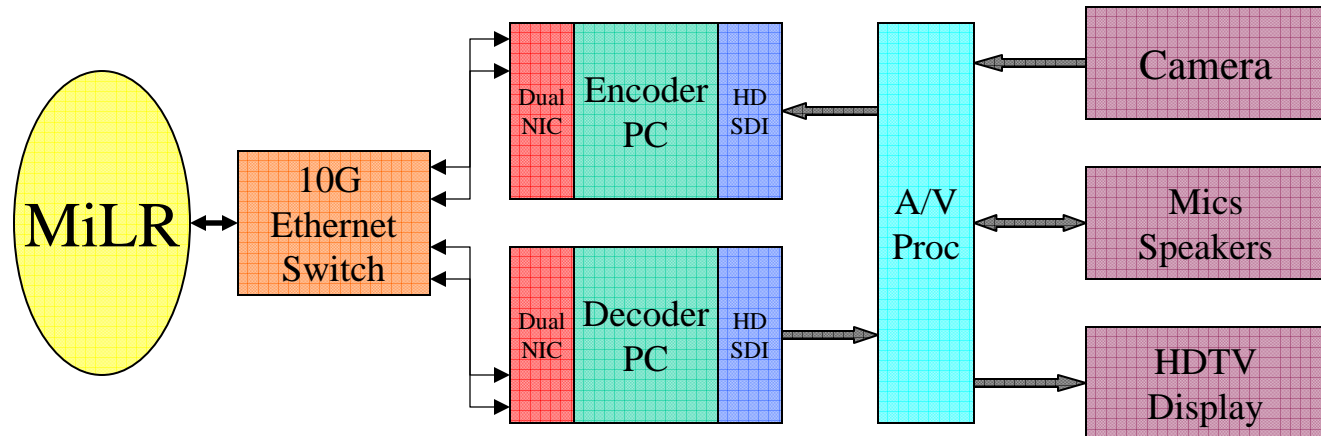

Diagram

WSU iHD1500 Endpoint

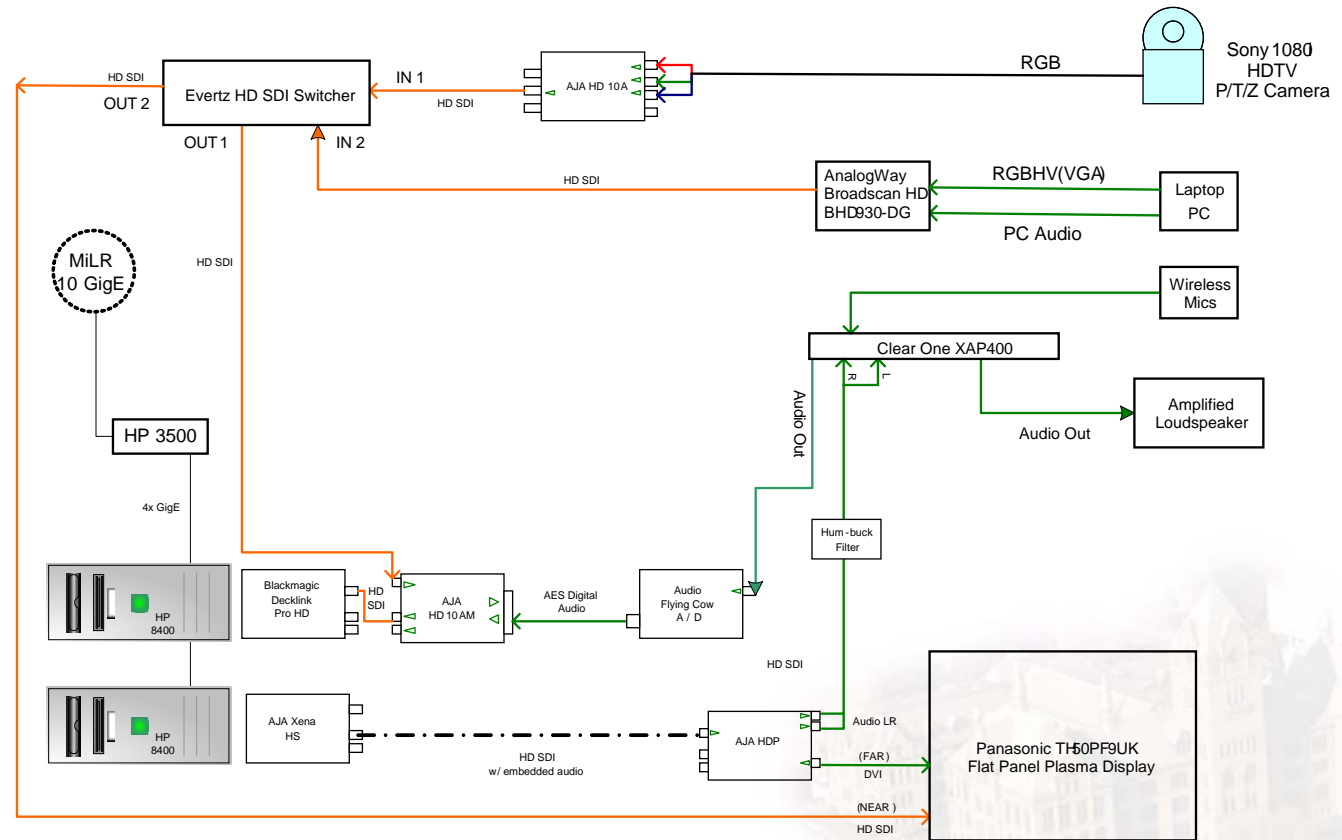

Prototype



Prototype



Futures

- Improve software & hardware
 - iHD Working Group
 - University of Washington
- Multicast
- Content capture
- New applications
- New platforms
- Automation
- Test, measurement, QC



Futures

- Phase 2
 - Build a better room
 - Move off prototype system
- Build on existing relationships
- Grant development
- Trust
- Help others

